

SGS® CR Series Shaft Grounding System CR23SB, CR23SB227

Application for 182T-254T, TEFC/ODP motors

Lorem ipsum

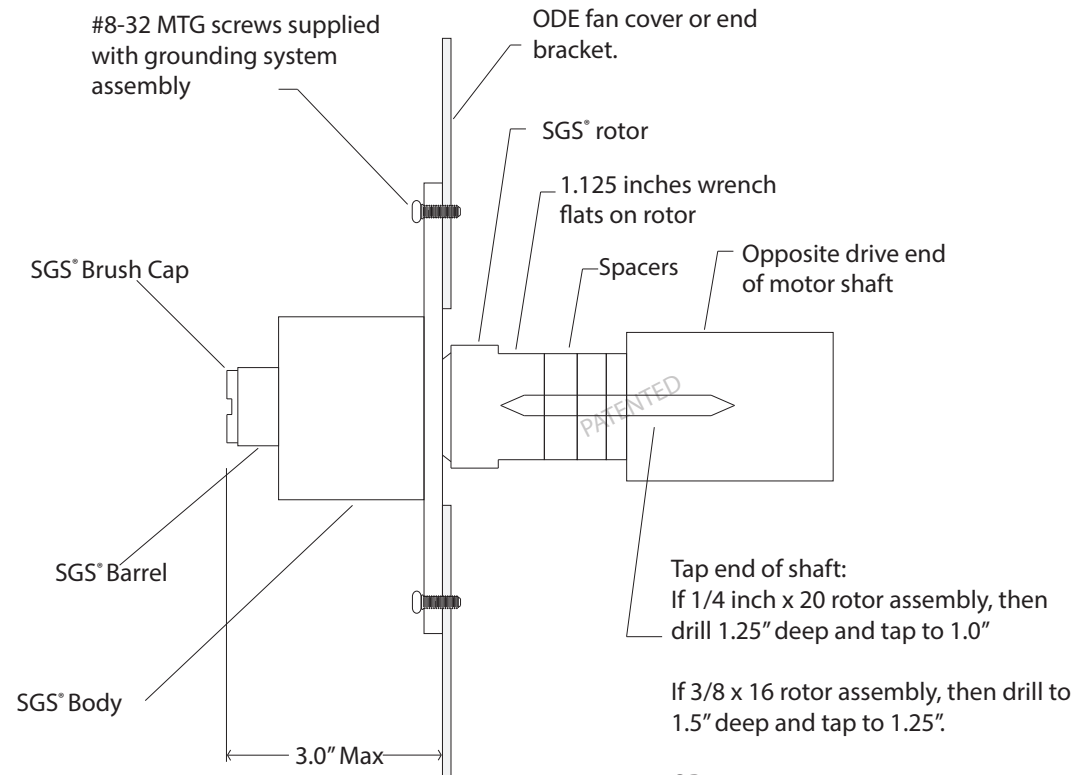
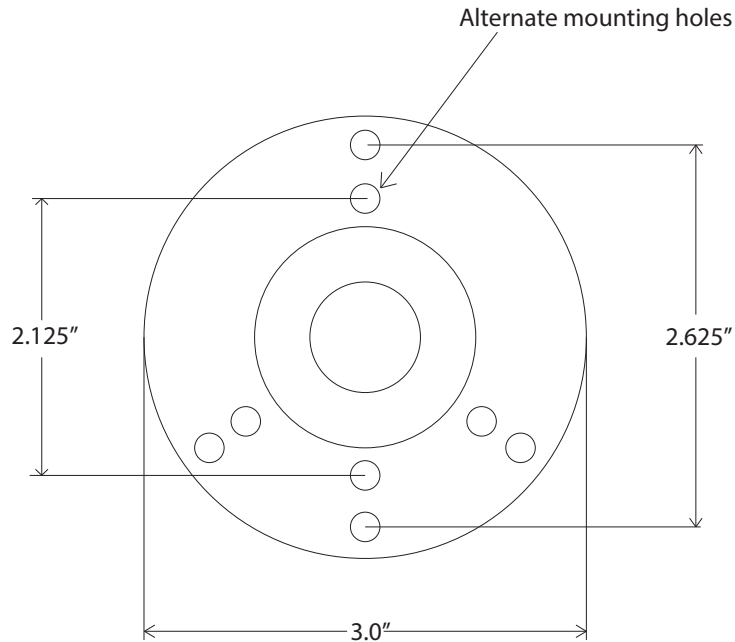

If rain guard or curved mounting surface present, then contact DP&A Sales to discuss possible needed adaptation.

OR

Custom adaptation as specified

Important: Make sure hole in end of motor shaft is drilled and tapped deep enough so that attachment stud does not bottom out in end of threads. Do not apply more than 15 ft-lbs of torque to rotor.

Not to scale, dimensions in inches

SGS® CR Series patented (Pat#5,661,356) shaft grounding system
DP&A Sales is exclusive worldwide factory distributor for SGS® products

Tel: +1 541-997-4068

Fax: +1 541-997-7278

sales@dpa-sales.com

www.shaftgrounding.com

MADE IN THE USA