

SGS® CR Series Shaft Grounding System CR23LB, CR23LB227

Application for 284T-365T TEFC Motors and 284T-449T ODP motors

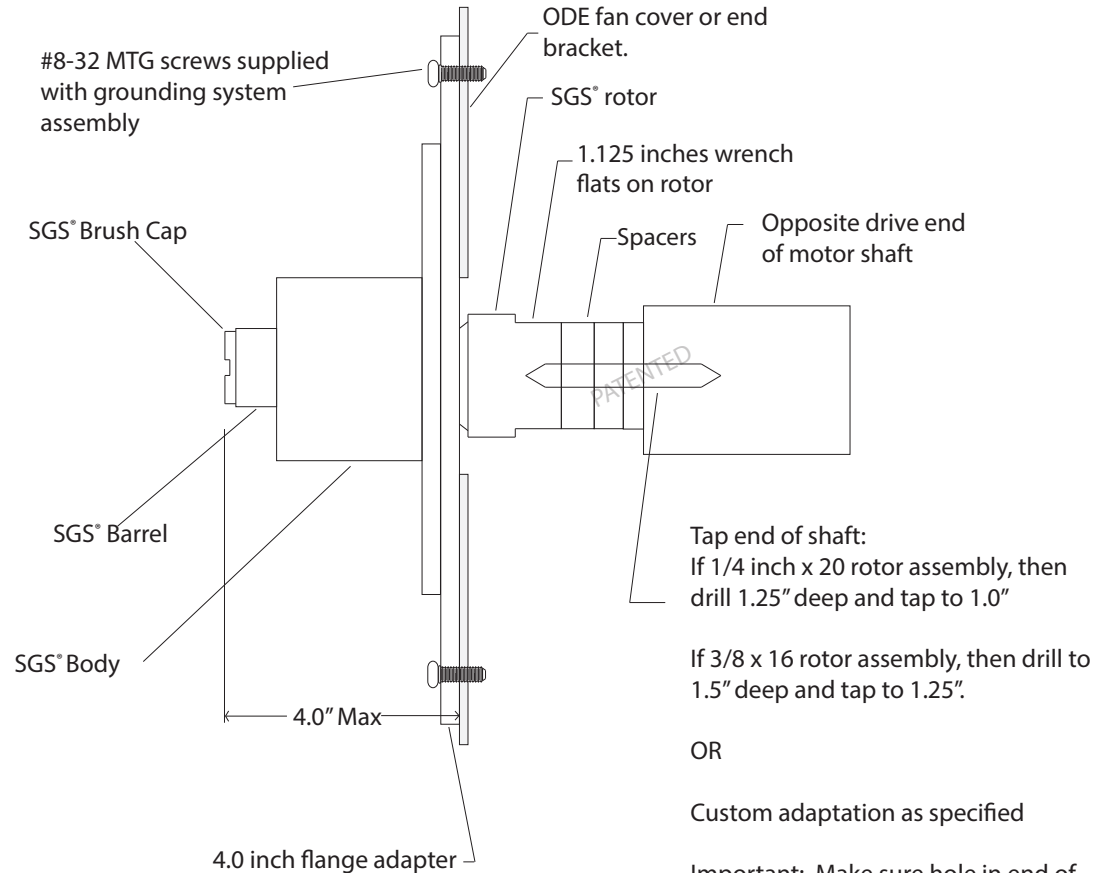
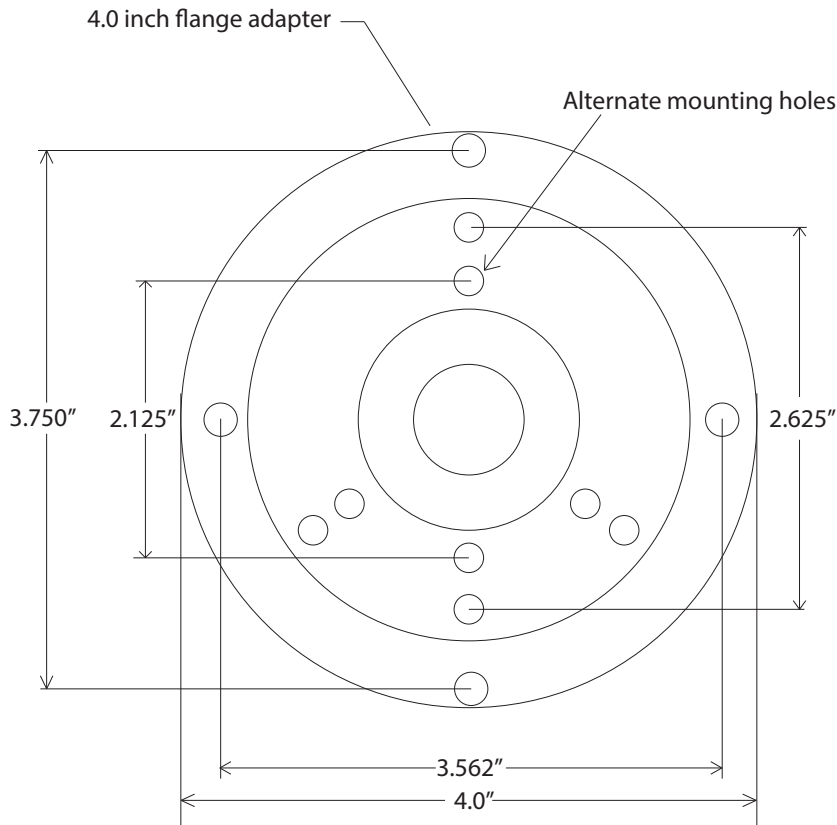

SGS® CR Series patented (Pat#5,661,356) shaft grounding system
 DP&A Sales is exclusive worldwide factory distributor for SGS® products
 Tel: +1 541-997-4068
 Fax: +1 541-997-7278
 sales@dpa-sales.com
 www.shaftgrounding.com

If rain guard or curved mounting surface present, then contact DP&A Sales to discuss possible needed adaptation.

Important: Make sure hole in end of motor shaft is drilled and tapped deep enough so that attachment stud does not bottom out in end of threads. Do not apply more than 15 ft-lbs of torque to rotor.

Not to scale, dimensions in inches