

SGS® CR Series Shaft Grounding System CR23VB, CR23VB227

Application for 449T and Above, TEFC Motors

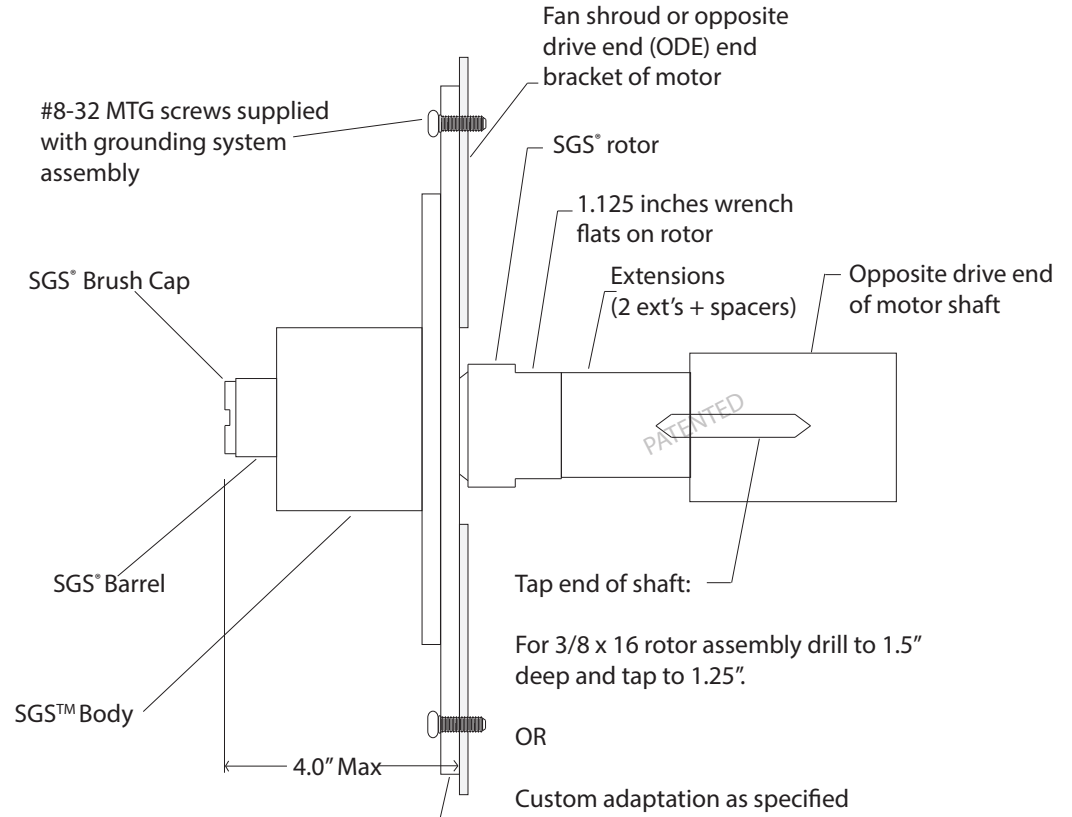
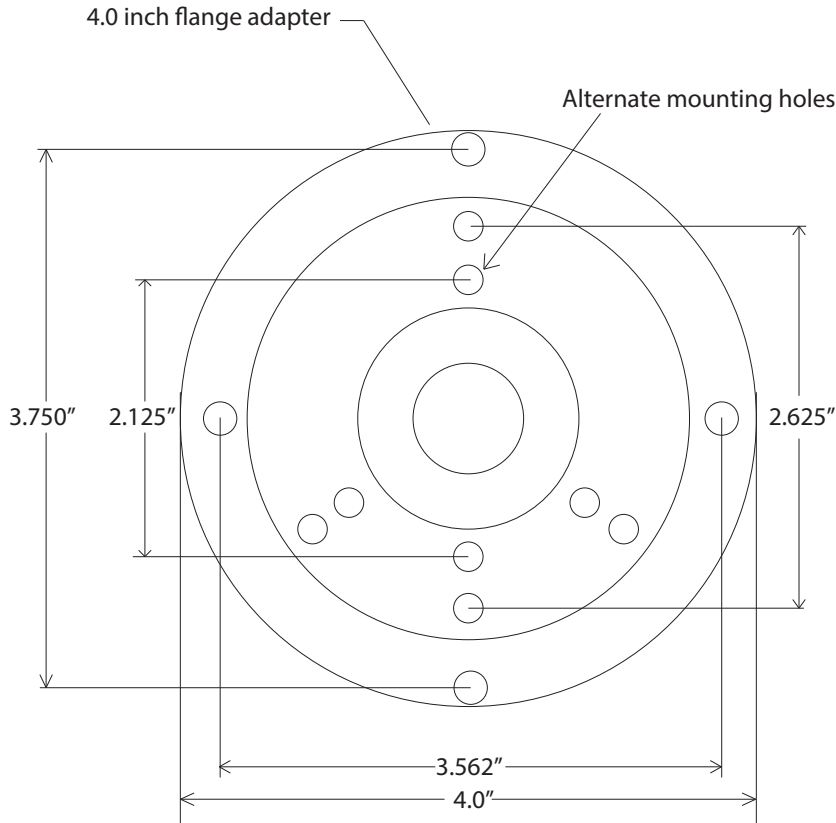

SGS® CR Series patented (Pat#5,661,356) shaft grounding system
 DP&A Sales is exclusive worldwide factory distributor for SGS® products
 Tel: +1 541-997-4068
 Fax: +1 541-997-7278
 sales@dpa-sales.com
 www.shaftgrounding.com

MADE IN THE USA

Not to scale, dimensions in inches

Important: Make sure hole in end of motor shaft is drilled and tapped deep enough so that attachment stud does not bottom out in end of threads. Do not apply more than 15 ft-lbs of torque to rotor.

If rain guard or curved mounting surface present, then contact DP&A Sales to discuss possible needed adaptation.